



L3HARRIS™
FAST. FORWARD.

MODEL H-411 ACOUSTO-OPTIC MODULATOR (AOM)

Radio frequency (RF) phase modulation for optical wavefronts

The L3Harris Model H-411 AOM represents a significant departure from conventional AOM technology. By changing only the phase of the RF source waveform to modulate optical intensity, the H-411 AOM assures constant input power is always applied to the device regardless of data rate conditions. As a result, transient thermal conditions that occur with conventional AOM drive techniques are largely eliminated, and beam pointing stability is significantly improved.

The H-411 AOM focuses light from a coherent optical source to a suitable beam waist within the optical medium, which is composed of low-loss, optical-grade tellurium dioxide crystal. The light is proportionally directed into a primary intense diffraction order at an angle that depends on the frequency of the applied RF source waveform. Advanced coherent transducer array technology, employed with precise digital drive technology, allows the H-411 AOM to be operated in either the RF phase modulation mode or a conventional on/off pulse RF mode for extended on/off contrast where beam-pointing stability is not critical. An L3Harris H-400 series compatible driver and interface cable are required for operation.

PERFORMANCE PARAMETERS

PARAMETER	SPECIFICATION
Unless otherwise noted, all specifications are at 532 nm wavelength	
Minimum on/off contrast ratio	30 dB
Nominal center frequency (fc)	80 MHz
Deflection bandwidth	65-95 MHz
Total deflection angle	3.8 mrad
Minimum diffraction efficiency	>80% @ fc
Optical beam diameter	0.25–3.5 mm (H) x 0.35 mm (max) (V)
Minimum rise time	45 ns (max) 0.25 mm (H)
Optical wavelength	488 nm–800 nm
Optical material	Tellurium dioxide



APPLICATIONS

- > Optical modulation in visible and near-infrared (NIR) systems requiring the ultimate in beam-pointing stability
- > Predeflection, modulation, pointing adjustment and micro-machining in visible and NIR laser systems

HIGHLIGHTS

- > Employs advanced coherent transducer array technology
- > Achieves excellent performance through use of high-frequency, bulk wave transducers and specialized fabrication techniques
- > Assures high reliability due to high-vacuum application of alloy-bonded transducers and low-loss, ultrahard, multilayer, ultraviolet-qualified antireflective coatings

TYPICAL PERFORMANCE AT 532 NM USING H-401D DRIVER

The following plots show measured and/or simulated performance for the H-411 AOM when used with an H-400 AOM series compatible driver. See specifications for guaranteed performance characteristics and applicable wavelength.

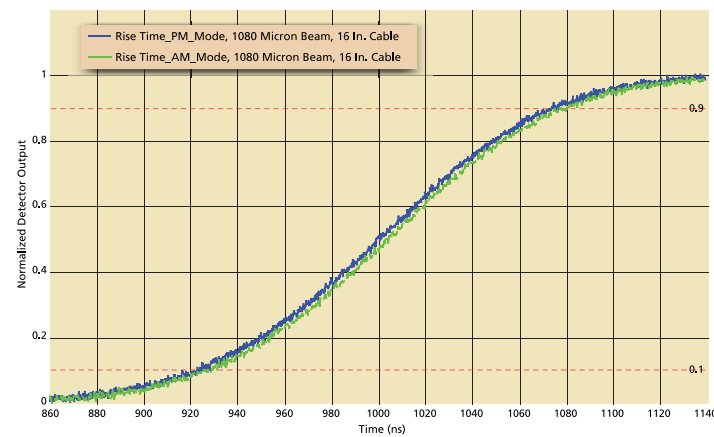
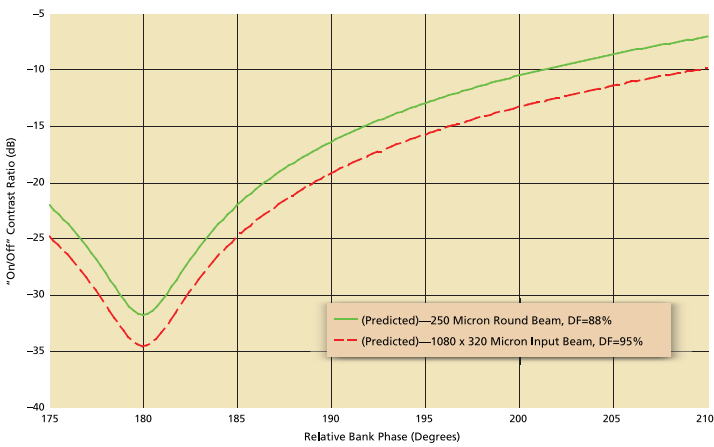
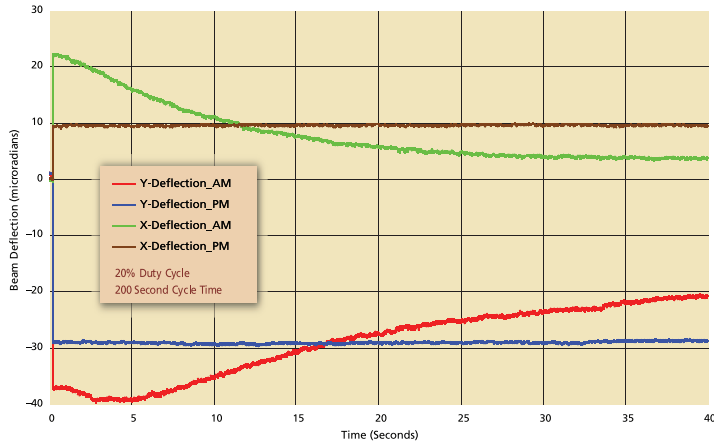

MECHANICAL CONFIGURATION

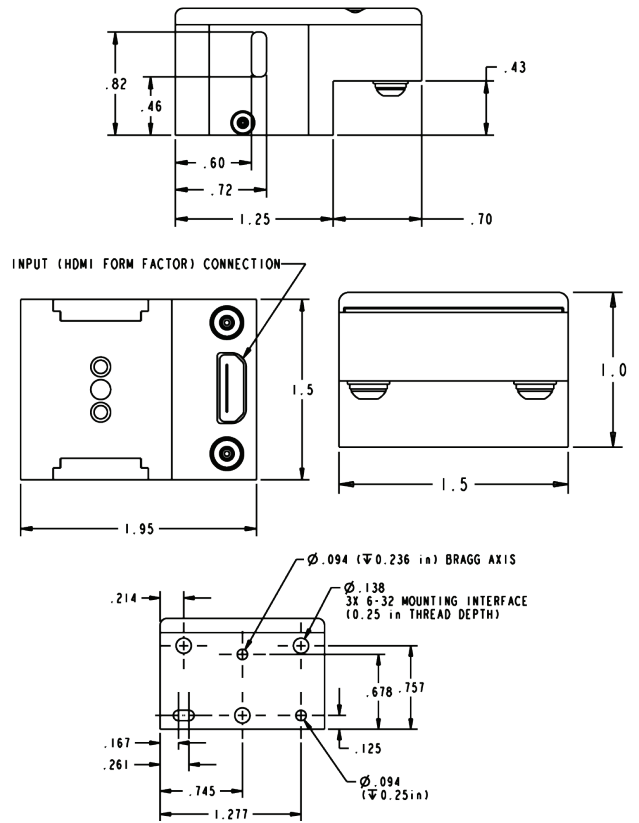

Part Ordering Configuration

H411-TE-WL-CF-MC-R

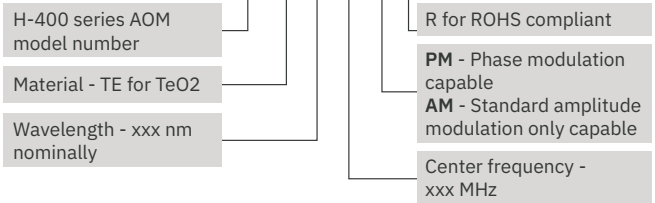

H411-TE-532-80-AM-R is the standard configuration. Please call the factory for additional configurations. Requires H-400 AOM series compatible driver and cable. Specifications subject to change without notice.

For additional information, email Acousto-Optics@L3Harris.com or visit www.L3Harris.com/Acousto-Optics.

Model H-411 Acousto-Optic Modulator

© 2020 L3Harris Technologies, Inc. | 02/2020 | 58169 | d0327 | EL

Nonexport-controlled Information

L3Harris Technologies is an agile global aerospace and defense technology innovator, delivering end-to-end solutions that meet customers' mission-critical needs. The company provides advanced defense and commercial technologies across air, land, sea, space and cyber domains.



1025 W. NASA Boulevard
Melbourne, FL 32919