

EDGE-HR

High-Resistance Deck Edge

Luminous element for flight deck identification (edge contour, tram lines) capable to operate in extreme environments. The high-resistance (HR) light stainless steel deck edge has been validated in severe mechanical and thermal stress including the F-35 landing applications. Available with omnidirectional or directional light emission.

MAIN CHARACTERISTICS:

- > Special design for high mechanical and thermal resistance
- > Flush to the deck: embedded into the compound covering the flight-deck
- > It can be connected in light series
- > Extremely low Radar Cross Section
- > NVG compatible (Stage-3)

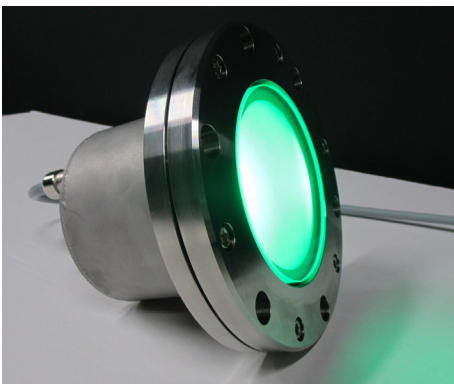

EDGE-HR

Qualified as per:

- > MIL-S-901D
- > MIL-STD-167
- > MIL-STD-810
- > MIL-STD-461

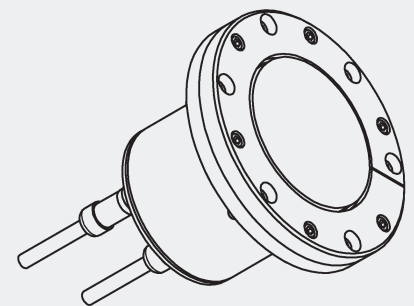

TECHNICAL SPECIFICATIONS

- > Electrical power: Max. 5 W
- > Light intensity:
 - Omnidirectional (Lambertian) > 60cd
 - Directional beam > 50cd between 0-20° elevation
±20° azimuth
- > Dimming: from 0 to 100% of luminous intensity
- > LED source life: > 100,000 hours
- > Overall dimensions and weight:
 - Diameter: 180 mm (7.0")
 - Height: 120 mm (4.7")
 - Weight: 4.5 kg approx.
- > Enclosure: Watertight/IP67 (EN60529)
- > Protection degree: IP67

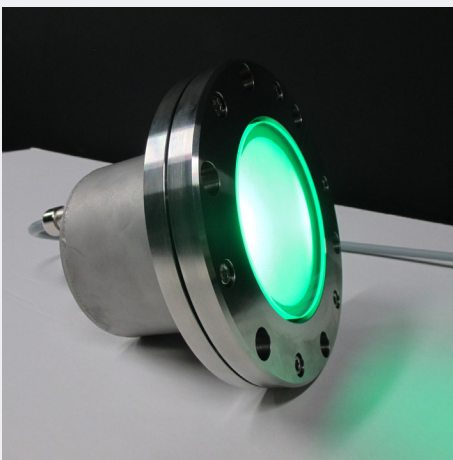
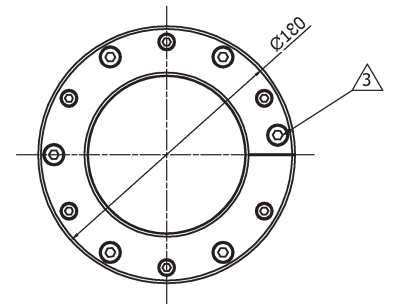
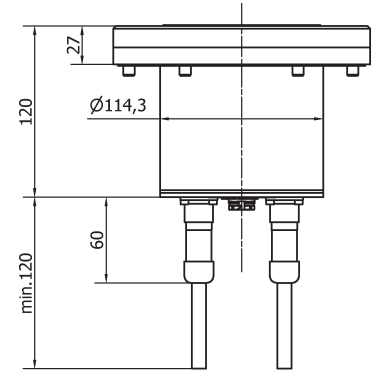

EDGE-HR

HIGH-RESISTANCE DECK EDGE

Available with omnidirectional or directional light emission.

Flush mounting using dedicated frame welded into the deck.

This sheet has been reviewed in accordance with the International Traffic in Arms Regulations (ITAR), 22 CFR Part 120.11, and the Export Administration Regulations (EAR), 15 CFR 734(3)(b)(3), and may be released without export restrictions.

This document consists of general capabilities information that is not defined as controlled technical data under ITAR Part 120.10 or EAR Part 772.

EDGE-HR

© 2022 L3Harris Technologies, Inc. | 04/2022

Data, including specifications, contained within this document are summary in nature and subject to change at any time without notice at L3Harris Technologies' discretion. Call for latest revision. All brand names and product names referenced are trademarks, registered trademarks, or trade names of their respective holders.

L3Harris Technologies is an agile global aerospace and defense technology innovator, delivering end-to-end solutions that meet customers' mission-critical needs. The company provides advanced defense and commercial technologies across air, land, sea, space and cyber domains.



L3HARRIS™
FAST. FORWARD.

1025 W. NASA Boulevard
Melbourne, FL 32919
t +39 05141377
Calzoni.General@L3Harris.com